

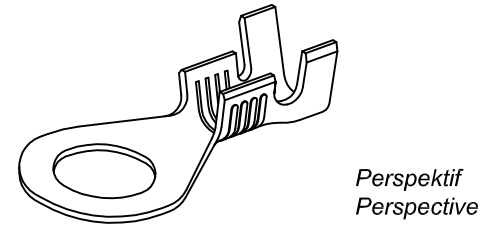

PARÇA KODU PART CODE	PARÇA ADI PART NAME	s ÖLÇÜSÜ (KALINLIK) s MEASURE (THICKNESS)	Malzeme Material	Kaplama / Coating		
				SN	AG	Nİ
MS 2427 DP	8 NO KABLO UÇ Ø8.4 =DP=	0.50±0.05	(CuZn30) Pirinç / Brass	-	-	-
MS 2427 RP	8 NO KABLO UÇ Ø8.4 =RP=	0.50±0.05	(CuZn30) Pirinç / Brass	-	-	-
MT 2427 DP	8 NO KABLO UÇ Ø8.4 =DP=	0.78±0.05	(CuZn30) Pirinç / Brass	-	-	-
MT 2427 RP	8 NO KABLO UÇ Ø8.4 =RP=	0.78±0.05	(CuZn30) Pirinç / Brass	-	-	-
TŞ 2427 DP	8 NO KABLO UÇ Ø8.4 =DP=	0.65±0.05	(CuZn30) Pirinç / Brass	-	-	-
TŞ 2427 RP	8 NO KABLO UÇ Ø8.4 =RP=	0.65±0.05	(CuZn30) Pirinç / Brass	-	-	-
TŞ 2427 RPK	8 NO KABLO UÇ Ø8.4 =RPK=	0.65±0.05	(CuZn30) Pirinç / Brass	+	-	-
TŞ 2427 RÇN	8 NO KABLO UÇ Ø8.4 =RÇN=	0.60±0.05	Paslanmaz Sac(430) / Stainless Steel	-	-	+

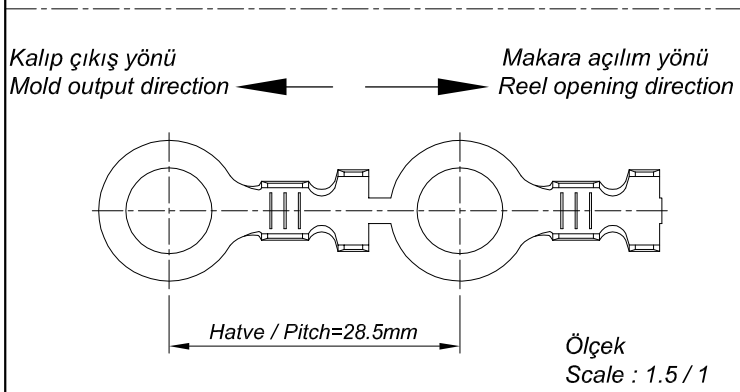
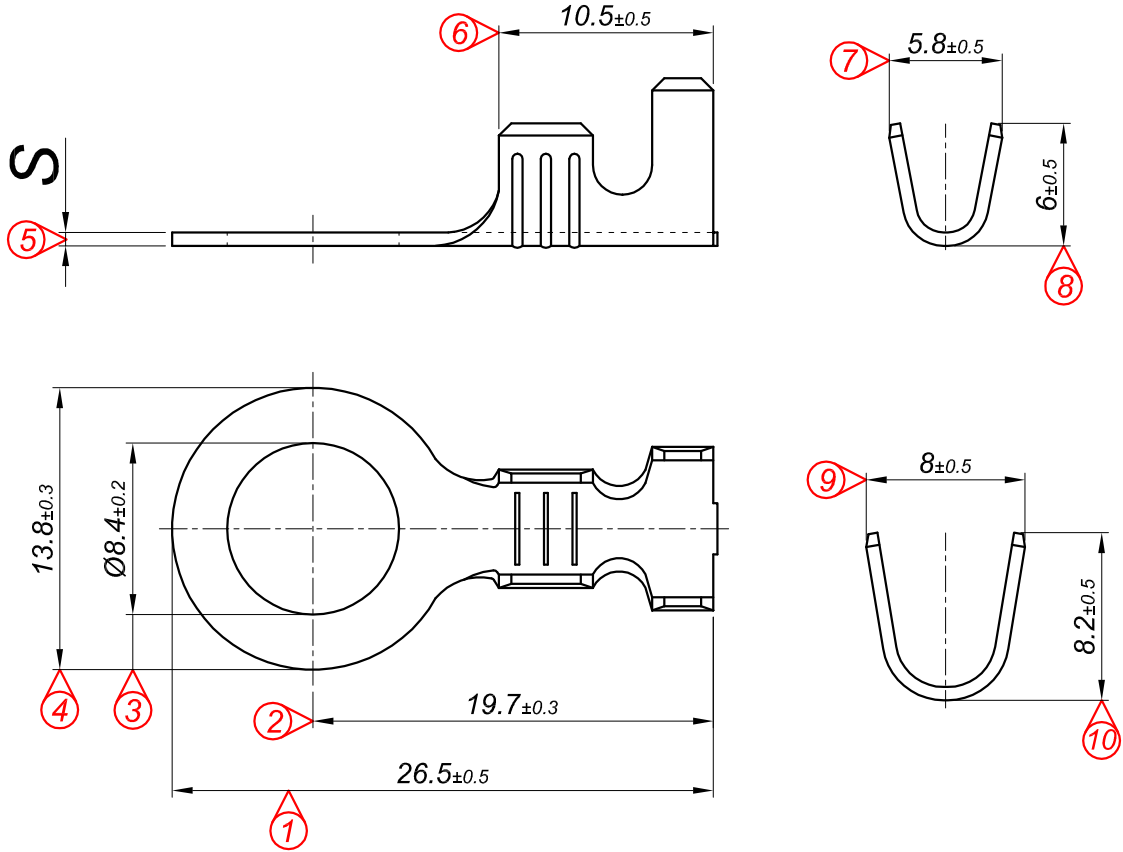

Kablo Kesiti
Wire Section : 2.50 - 6 mm²

Resim üzerinden ölçü almayınız
do not measure on drawing

Tarih / Date	25.07.2013	İmza / Signature	Ölçek / Scale			
Çizen / Desing	M.Yağcı		3 / 1	No		
Onay / Approval	S.Gölcük				Değişiklik / Revision	Tarih/Date
	Parça Adı: Part Name	8 NO KABLO UCU Ø8.4			Parça Kodu: Part Code	TŞ 2427